

Magnet switch iKA509

for intermediate position
measurement and end position
monitoring by means of
magnetically operated contacts

- Rugged design
- Connection via terminal housing
- Any fitting position
- Almost inertia-free due to use of reed contacts
- For extremely large switching distances
- Negligible wear and maintenance free as contacts are operated by magnets
- Type of protection: IP 54 according to EN 60529/IEC 529
- Ex-approval: I M2 EEx ia I intrinsically safe according to Directive 94/9/EC



**Magnet switch iKA509 used for
hoisting cage position monitoring**

iKA509

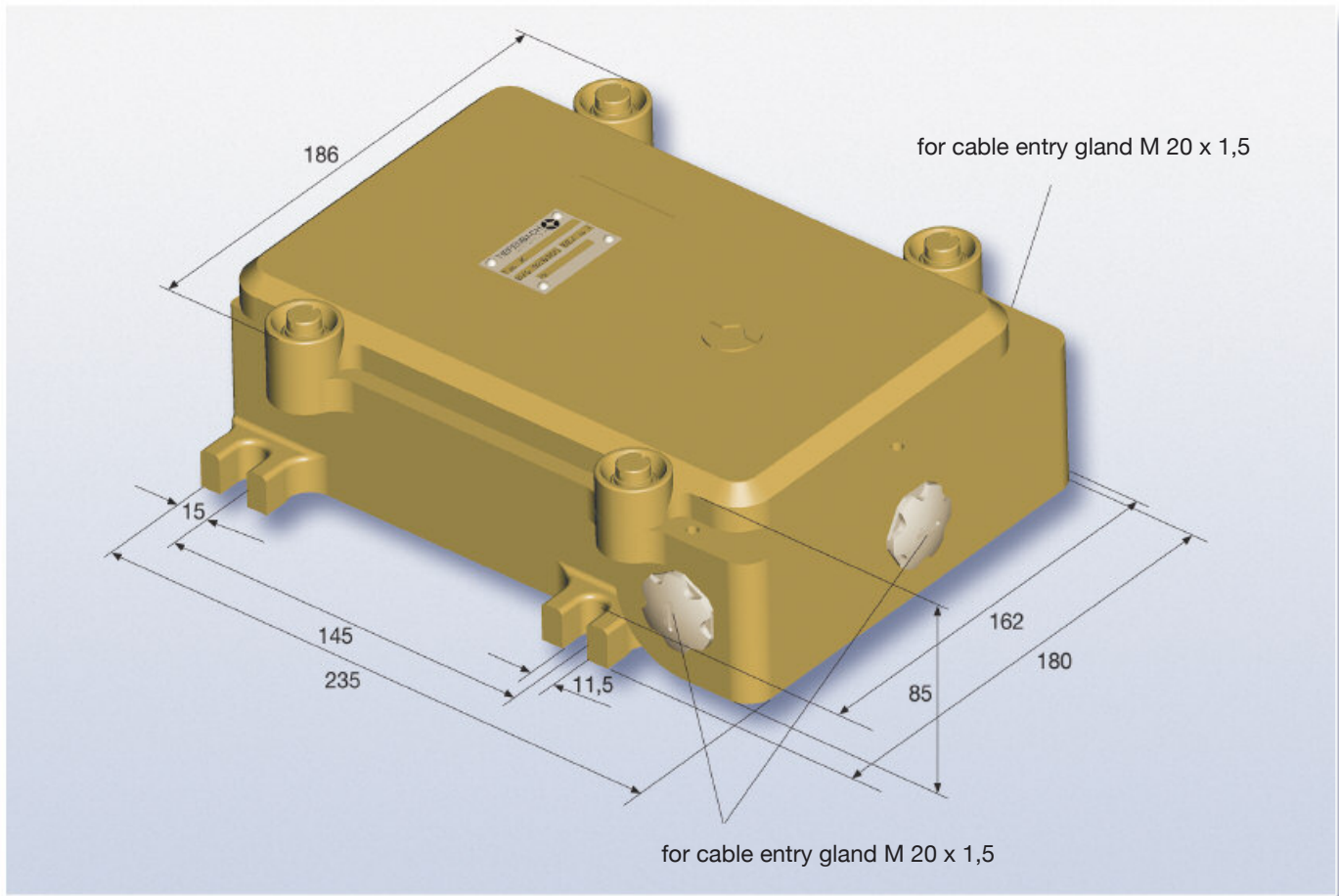

switching distance	magnet switch on non-ferritic base, magnet on iron			
switching magnet	M8	M9/2	M9/4	M9/6
pulse contact	60 mm	70 mm	110 mm	120 mm
latching-type contact	90 mm	110 mm	160 mm	180 mm

switch equipment	contact connection		Code letters for diode connection			
	without connection, no numbers or letters	letters for connection with 5 ≙ NAMUR	A	D	E	G
1 one reed contact						
2 two reed contacts, electrically isolated, identical switching behaviour						
3 two reed contacts, electrically isolated, anticoincidence switching behaviour						

Extract of our connection list. Further connections upon request.



iKA509

FUNCTION AND DESIGN

The magnet switch is equipped with reed contacts. These can be designed as normally open or change-over contacts. The contacts are activated by a permanent magnet passing by. The physical connection between the air gap of the contact blades getting smaller when the contact closes and the quadratic rise of the magnetic field results in a sudden activation. It is possible to choose between two switching behaviours:

- monostable (pulse switch)
- bistable (latching-type switch)

In the monostable-type switch, the reed contact change-over is effected analogous with the influence by the magnetic field. After the permanent magnet has been removed the respective contact will return to its original position. A maximum of two change-over contacts can be installed.

The latching-type contact as bistable switch has storage characteristics. To this end, the reed contact is magnetically „pretensioned“ in the two switching positions by two holding magnets. By means of the stronger switching magnet the switch can be set or reset. This design also allows to install two change-over contacts.

To permit line monitoring for equipment integrated in control or monitoring circuits relevant to safety the contacts of the magnet switch can be connected with diode or resistor combinations. This allows for monitoring lines to detect broken conductors and short circuits according to the half-wave or full-wave principle as well as according to NAMUR.

The switch combination is embedded in cast resin. For the attenuation of shocks and vibrations which might result in an unintentional operation of the reed contacts, the switching unit is fastened on rubber bonded metals and located in a gunmetal housing. The gunmetal housing also contains the terminals. This arrangement ensures adequate safety with respect to explosion protection and against mechanical damage.

Application

- The magnet switch can be used for all applications where extremely large switching distances are required for intermediate position measurement or end position monitoring. The connection housing allows to integrate the switch without any problems into new or retrofit installations.
- Due to the large switching distance possible this type of switch is often used for position measurements and monitoring functions in the shaft area.
- The magnet switch can also be placed on ferritic material, same as the switching magnet. In this connection it should be noted that when installing the magnet switch on iron the magnetic field will be weakened as the switching magnet approaches which will reduce the switching distance. If, on the other hand, the permanent magnet is mounted on iron, the magnetic field will be strengthened.
- **The largest possible switching distance can be achieved by installing the magnet switch on a non-ferritic base and mounting the permanent magnet on iron.**



iKA509

TECHNICAL DATA

Switching distance	depending on the magnet used (see table page 2)
Type of contact	reed contact
Switching behaviour	monostable (pulse switch) or bistable (latching-type switch)
Contact equipment	max. 2 change-over contacts
Contact connection	diode and resistor combinations for line monitoring
Contact capacity	for intrinsically safe circuits
Response time	≤ 2 ms
Releasing time	≤ 0.2 ms
Operating life	> 10 ⁹ switching operations
Type of connection	terminal housing
Temperature range	- 20 °C to 85 °C
Fitting position	any
Type of protection	IP 54 according to EN 60529/IEC 529
Ex-approval	I M2 EEx ia I acc. to Directive 94/9/EC
Certificate number	BVS 03 ATEX E 167

TYPE CODE AND ORDERING INFORMATION

* K A 509 K * * * *	Contact connection acc. to table (see page 2) Without connection the last place will be omitted
	Contact type code: 2 ► NO max. switching current 1,3 A 4 ► NO max. switching current 3 A 5 ► change-over contact
	Number of reed contacts
	Switching behaviour: 1 ► pulse switch 2 ► latching-type switch
	Type of connection: terminal
	Series
	Design acc. to ATEX
	Magnet switch
	i ► intrinsically safe w ► non-explosionproofed version

TYPICAL EXAMPLE

iKA509K125D	<ul style="list-style-type: none"> ■ Intrinsically safe magnet switch, acc. to ATEX ■ Connection via terminal ■ Pulse switch 	<ul style="list-style-type: none"> ■ 2 Change-over contacts ■ Connection with 2 antiparallel diodes each change-over contact
--------------------	---	--

Subject to technical alterations · Version 08/12